



**DIPLOMATIC
HYDRAULICS**

41 310/105 ED

DS5

SOLENOID OPERATED DIRECTIONAL CONTROL VALVE SERIES 12



SUBPLATE MOUNTING ISO 4401-05 (CETOP 05)

p max 320 bar
Q max 150 l/min

MOUNTING INTERFACE

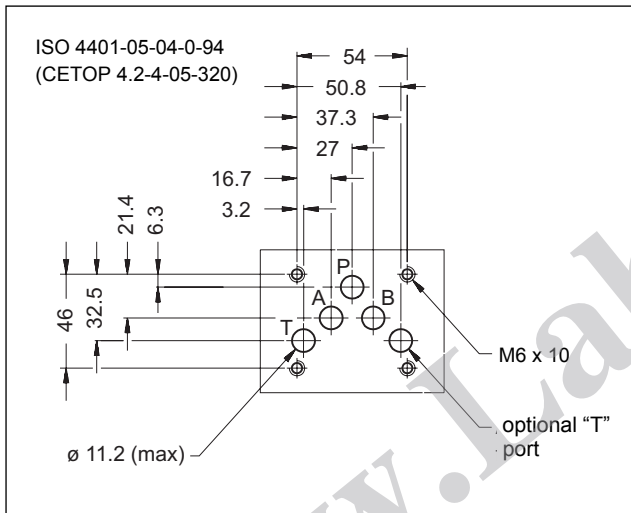

OPERATING PRINCIPLE

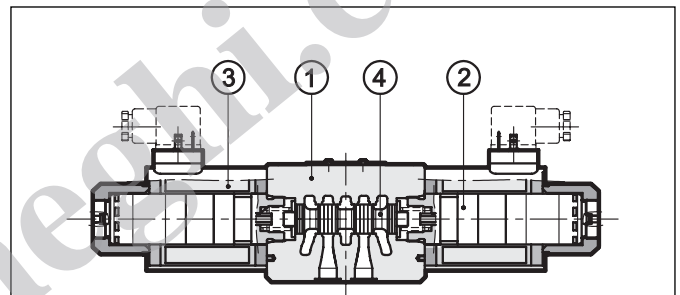

- Direct acting, subplate mounting directional control valve, with mounting surface according to ISO 4401 (CETOP RP121H).

- The valve body ① is made with high strength iron castings provided with wide internal passages in order to minimize the flow pressure drop. Wet armature solenoids ② with interchangeable coils ③ are used (for further information on solenoids see par. 7).

- The valve is supplied with 3 or 4 way designs and with several interchangeable spools ④ with different porting arrangements.

-The valve is available with DC or AC solenoids. DC solenoids can also be fed with AC power supply, by using connectors with a built-in rectifier bridge (see cat. 49 000).

- The DC solenoids DS5 directional valve is available in the following special versions:
- version with Y external subplate drain port, (see par. 12.2).
- version with fixed restrictor for soft-shifting (see par. 12.3)
- version with adjustable "soft-shifting" device (see par. 12.4)

PERFORMANCE RATINGS (with mineral oil of viscosity of 36 cSt at 50°C)

		DC	AC
		Maximum operating pressure P - A - B ports	
T port	standard version	210	140
	version with Y port	320	-
Maximum flow rate	l/min	150	120
Pressure drop $\Delta p-Q$	see par. 4		
Operating limits	see par. 6		
Electrical features	see par. 7		
Electrical connections	plug for connector DIN 43650		
Ambient temperature range	°C	-20 / +50	
Fluid temperature range	°C	-20 / +80	
Fluid viscosity range	cSt	10 ÷ 400	
Recommended viscosity	cSt	25	
Fluid contamination degree	according to NAS 1638 class 10		
Mass:	single solenoid valve	kg	4,4
	double solenoid valve	kg	5,9
			3,6
			4,3



1 - IDENTIFICATION CODE

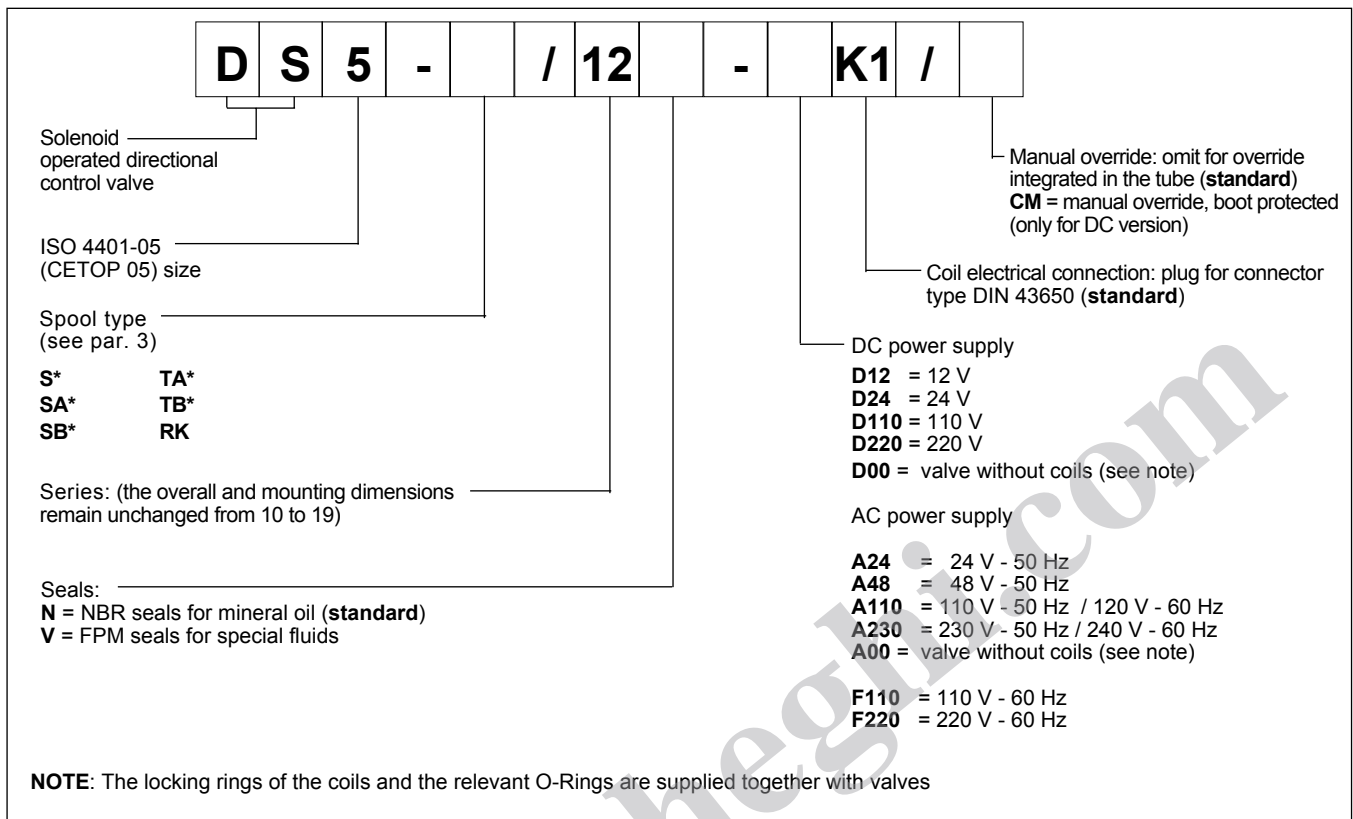

2 - HYDRAULIC FLUIDS

Use mineral oil-based hydraulic fluids HH, HL or HM type, according to ISO 6743-4.

For fluids HFDR type (phosphate esters) use FPM seals (code V).

For the use of other fluid types such as HFA, HFB, HFC, please consult our technical department.

Using fluids at temperatures higher than 70°C causes a faster degradation of the fluid and of the seals characteristics.

The fluid must be preserved in its physical and chemical characteristics.



3 - CONFIGURATIONS

Type **S***:
2 solenoids - 3 positions
with spring centering

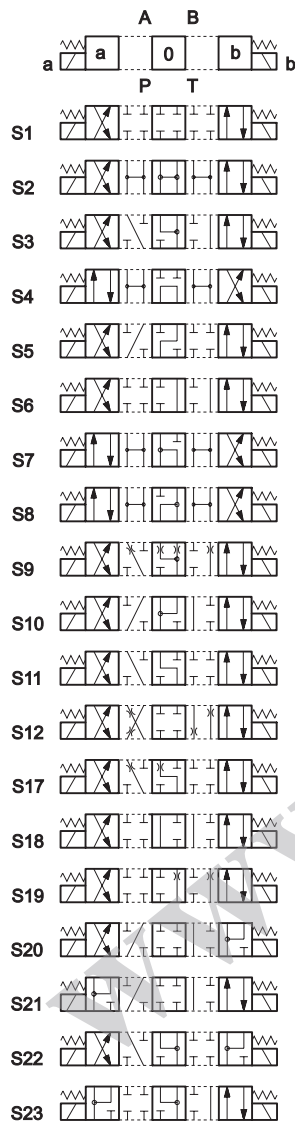

Type **SA***:
1 solenoid side A
2 positions (central + external)
with spring centering

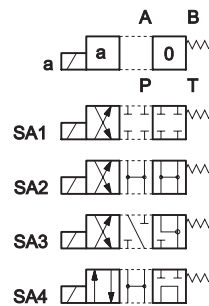

Type **SB***:
1 solenoid side B
2 positions (central + external)
with spring centering

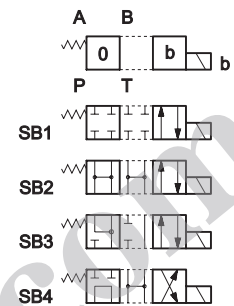

Type **TA**:
1 solenoid side A
2 external positions
with return spring

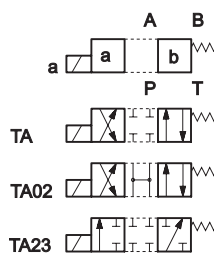

Type **TB**:
1 solenoid side B
2 external positions
with return spring

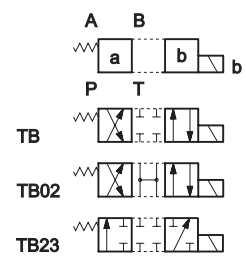

Type **RK**:
2 solenoids - 2 positions
with mechanical retention

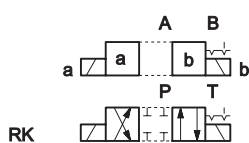

Besides the diagrams shown, which are the most frequently used, other special versions are available: consult our technical department for their identification, feasibility and operating limits.



4 - PRESSURE DROPS Δp -Q (obtained with viscosity 36 cSt at 50 °C)

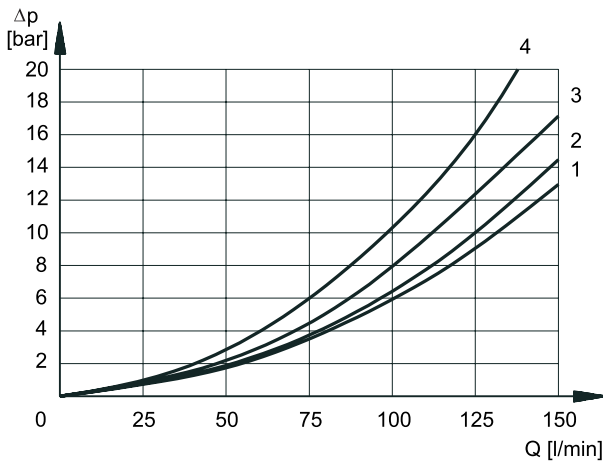

PRESSURE DROPS WITH VALVE ENERGIZED

SPOOL TYPE	FLOW DIRECTION			
	P-A	P-B	A-T	B-T
	CURVE S ON GRAPH			
S1, SA1, SB1	2	2	1	1
S2, SA2, SB2	3	3	1	1
S3, SA3, SB3	3	3	2	2
S4, SA4, SB4	1	1	2	2
S5	2	1	1	1
S6, S11	3	3	2	2
S7, S8	1	1	2	2
S9	3	3	2	2
S10	1	1	1	1
S12	2	2	1	1
S17, S19	2	2	1	1
S18	1	2	1	1
S20, S21				
S22, S23				
TA, TB	3	3	2	2
TA02, TB 02	3	3	2	2
TA23, TB23	4	4		
RK	3	3	2	2

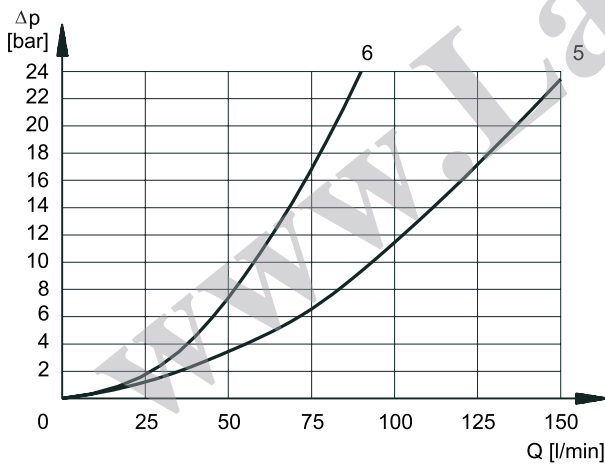

PRESSURE DROPS WITH VALVE IN DE-ENERGIZED POSITION

SPOOL TYPE	FLOW DIRECTION				
	P-A	P-B	A-T	B-T	P-T
	CURVES ON GRAPH				
S2, SA2, SB2					5
S3, SA3, SB3			6	6	
S4, SA4, SB4					5
S5		3			
S6				6	
S7					
S8					
S9					
S10					
S11			6		
S17					
S18	3				
S19					
S22					
S23					

5 - SWITCHING TIMES

The values indicated are obtained according to ISO 6403 standard, with mineral oil viscosity 36 cSt at 50°C.

SOLENOID TYPE	TIMES	
	ENERGIZING	DE-ENERGIZING
DC	100 ÷ 150 ms	20 ÷ 50 ms
AC	15 ÷ 30 ms	20 ÷ 50 ms



6 - OPERATING LIMITS

The curves define the flow rate operating fields according to the valve pressure of the different versions.

The values have been obtained according to ISO 64003 norm with solenoids at rated temperature and supplied with voltage equal to 90% of the nominal voltage.

The values have been obtained with mineral oil, viscosity 36 cSt, temperature 50 °C and filtration according to NAS 1638 class 7.

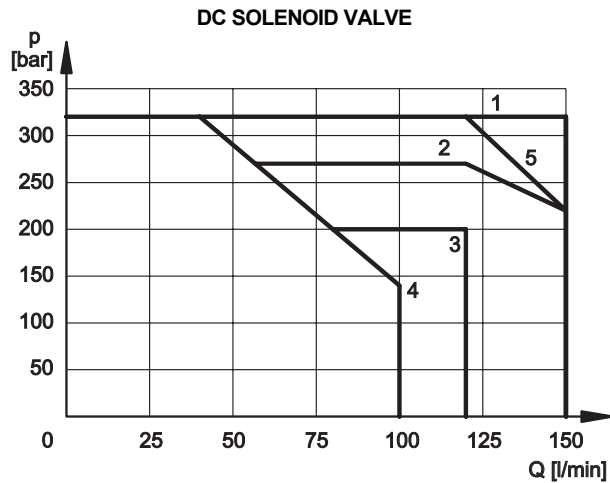

SPOOL TYPE	CURVE	
	P-A	P-B
S1,SA1,SB1	1	1
S2, SA2, SB2	1	1
S3, SA3, SB3	2	2
S4, SA4, SB4	3	3
S5	1	1
S6	2	1
S7	4	4
S8	4	4
S9	1	1
S10	1	1
S11	1	2
S12	1	1

SPOOL TYPE	CURVE	
	P-A	P-B
S17	1	3
S18	1	1
S19	3	1
S20		
S21		
S22		
S23		
TA, TB	5	5
TA02, TB02	3	3
TA23, TB23	1	1
RK	1	1

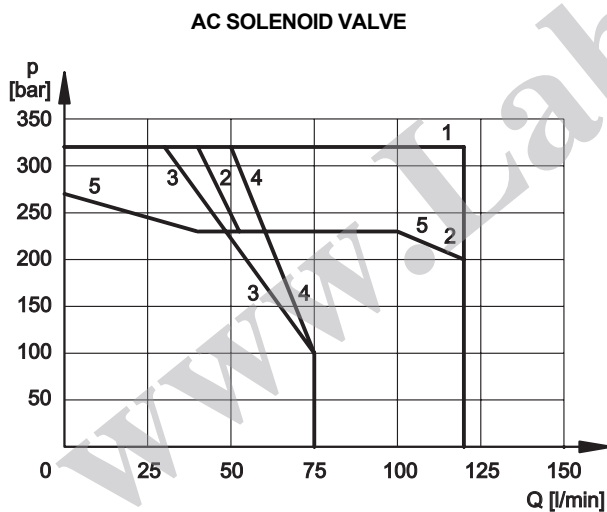

SPOOL TYPE	CURVE	
	P-A	P-B
S1,SA1,SB1	1	1
S2, SA2, SB2	2	2
S3, SA3, SB3	2	2
S4, SA4, SB4	4	4
S5	1	1
S6	2	1
S7	3	3
S8	3	3
S9	2	2
S10	1	1
S11	1	2
S12	1	1

SPOOL TYPE	CURVE	
	P-A	P-B
S17	1	5
S18	1	1
S19	5	1
S20		
S21		
S22		
S23		
TA, TB	1	1
TA02, TB02	5	5
TA23, TB23	1	1
RK	1	1

NOTE: The values indicated in the graphs are relevant to the standard solenoid valve. The operating limits can be considerably reduced if a 4-way valve is used with port A or B plugged.

Flow and pressure performances of soft-shifting configurations (options /F* and /S) are influenced by the set shifting time.

For further information on these applications please consult our Technical Department.



7 - ELECTRICAL FEATURES

7.1 Solenoids

These are essentially made up of two parts: tube and coil. The tube is threaded into the valve body and includes the armature that moves immersed in oil, without wear. The inner part, in contact with the oil in the return line, ensures heat dissipation.

The coil is fastened to the tube by a threaded ring, and can be rotated, to suit the available space.

Note 1: In order to further reduce the emissions, use of type H connectors is recommended. These prevent voltage peaks on opening of the coil supply electrical circuit (see CAT. 49 000).

7.2 Current and absorbed power for DC solenoid valve

The table shows current and power consumption values relevant to the different coil types for DC.

The rectified current supply takes place by fitting the valve with an alternating current source (50 or 60 Hz), rectified by means of a bridge built-in to the "D" type connectors (see cat. 49 000).

7.3 Current and absorbed power for AC solenoid valve

The table shows current and power consumption values at inrush and at holding, relevant to the different coil types for AC current.

SUPPLY VOLTAGE FLUCTUATION	± 10% Vnom
MAX SWITCH ON FREQUENCY	15.000 ins/hr
DUTY CYCLE	100%
ELECTROMAGNETIC COMPATIBILITY (EMC) EMISSIONS (see note 1)	EN 50081-1
IMMUNITY	EN 50082-2
LOW VOLTAGE	in compliance with 73/23/EEC 96/68/EEC
Class of protection: Atmospheric agents (CEI EN 60529) Coil insulation (VDE 0580) Impregnation	IP 65 (see note 2) class H class F

Note 2: The IP65 protection degree is guaranteed only with the connector correctly connected and installed.

Coils for direct current (values ± 5%)

Suffix	Nominal voltage [V]	Resistance at 20°C [ohm]	Current consumpt. [A]	Power consumpt. [W]	Coil code
D12	12	3 - 3,4	3,81	45,8	1902870
D24	24	12 - 14	1,90	45,3	1902871
D110	110	235-270	0,44	48,4	1902872
D220	220	960-1110	0,21	47,1	1902873

Note: It is necessary to allow, when supplying the valve with rectified current, a reduction of the operating limits by 5-10% approx.

Coils for alternating current (values ± 5%)

Suffix	Nominal voltage [V]	Frequency [Hz]	Resistance at 20°C [ohm]	Current consumption at inrush [A]	Current consumption at holding [A]	Power consumption at inrush [VA]	Power consumption at holding [VA]	Coil code
A24	24	50	0,53	25	3,96	600	95	1902890
A48	48		2,09	12,5	2,3	600	110	1902891
A110	110V-50Hz	50/60	10,9	5,2	0,96	572	105	1902892
	120V-60Hz		10,9	5,2	0,89	572	105	
A230	230V-50Hz		52,7	2,8	0,46	644	105	1902893
	240V-60Hz		52,7	2,8	0,38	644	105	
F110	110	60	8,80	5,2	0,95	572	105	1902894
F220	220		35,2	2,7	0,48	594	105	1902895

8 - INSTALLATION

Configurations with centering and return springs can be mounted in any position; type RK valves - without springs and with mechanical detent - must be mounted with the longitudinal axis horizontal. Valve fixing is by means of screws or tie rods, with the valve mounted on a lapped surface, with values of planarity and smoothness that are equal to or better than those indicated in the drawing. If the minimum values of planarity and/or smoothness are not met, fluid leakage between valve and mounting surface can easily occur.

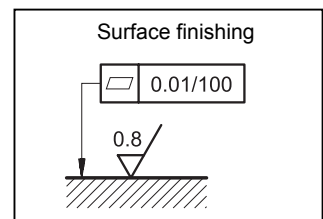

9- ELECTRIC CONNECTORS

The solenoid valves are not supplied with connector. Connectors must be ordered separately.

For the identification of the connector type to be ordered, please see catalogue 49 000.



10 - OVERALL AND MOUNTING DIMENSIONS FOR DC SOLENOID VALVES

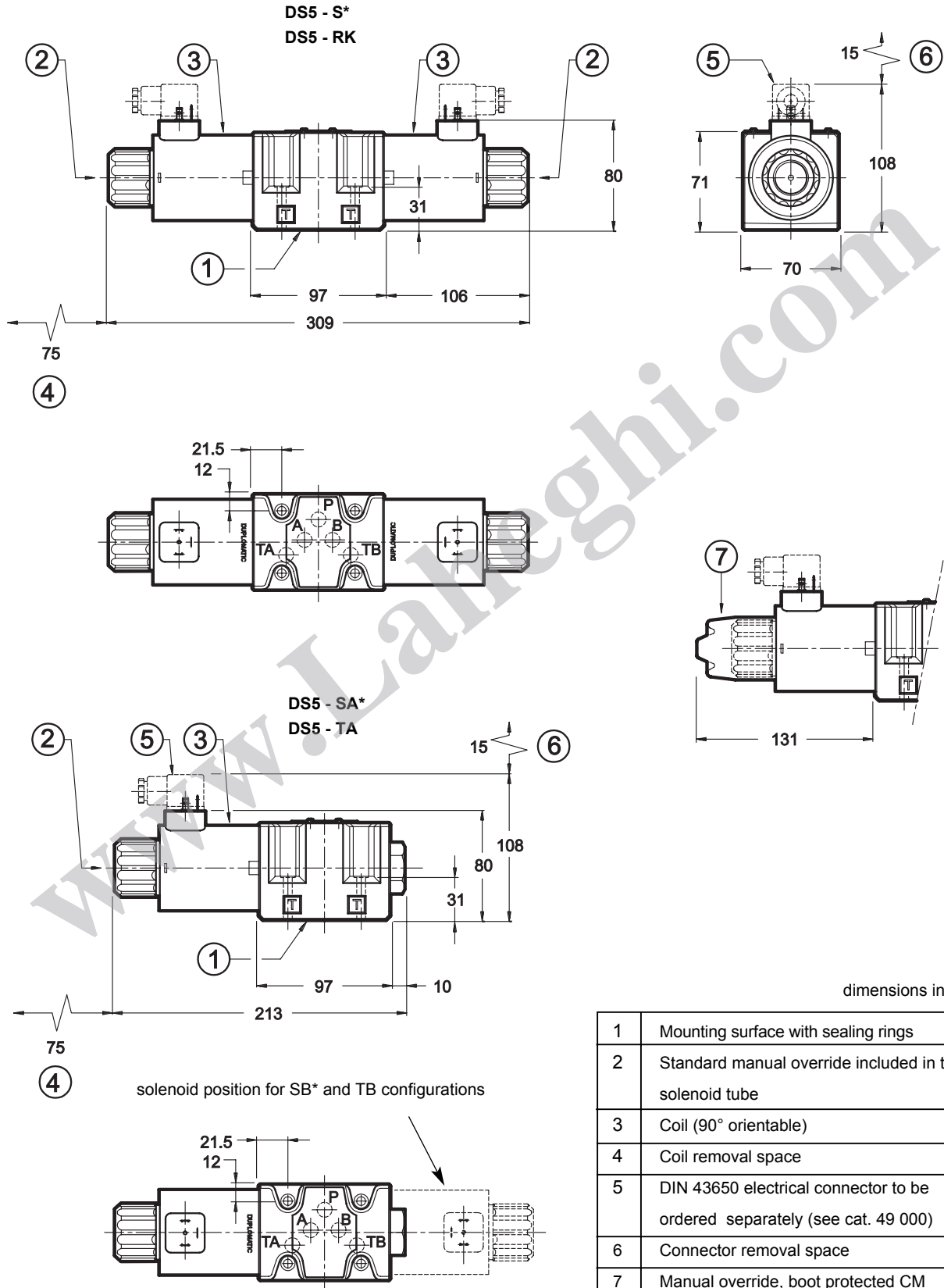

See par. 15 for fastening bolts and sealing rings



11 - OVERALL AND MOUNTING DIMENSIONS FOR AC SOLENOID VALVES

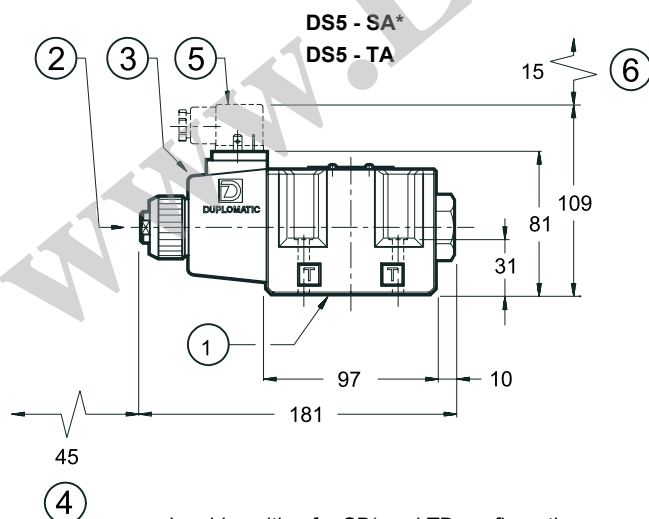
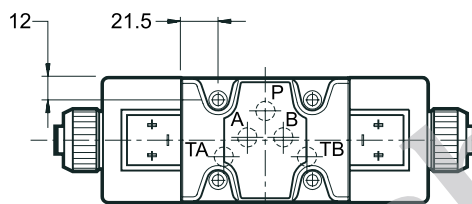
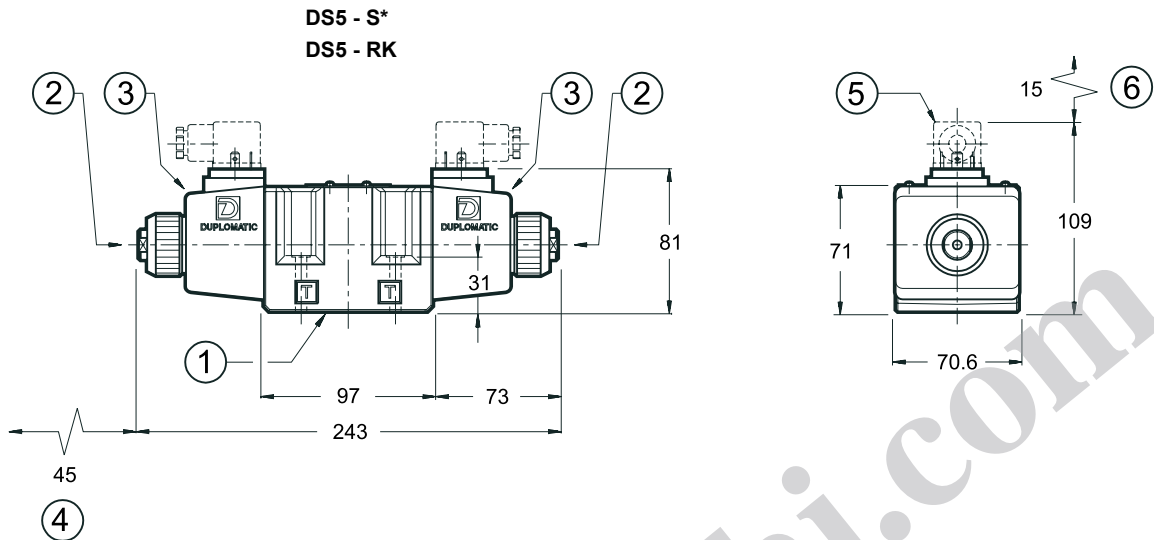

solenoid position for SB* and TB configurations

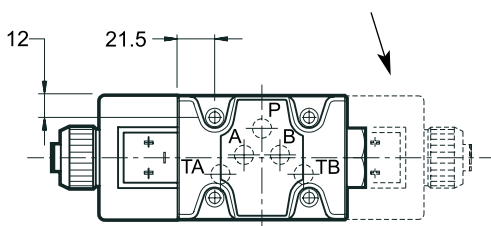

dimensions in mm

1	Mounting surface with sealing rings
2	Standard manual override included in the solenoid tube
3	Coil (360° orientable)
4	Coil removal space
5	DIN 43650 electrical connector to be ordered separately (see cat. 49 000)
6	Connector removal space

See par. 15 for fastening bolts and sealing rings



12 - SPECIAL VERSIONS FOR DC SOLENOID VALVE

12.1 - Identification code

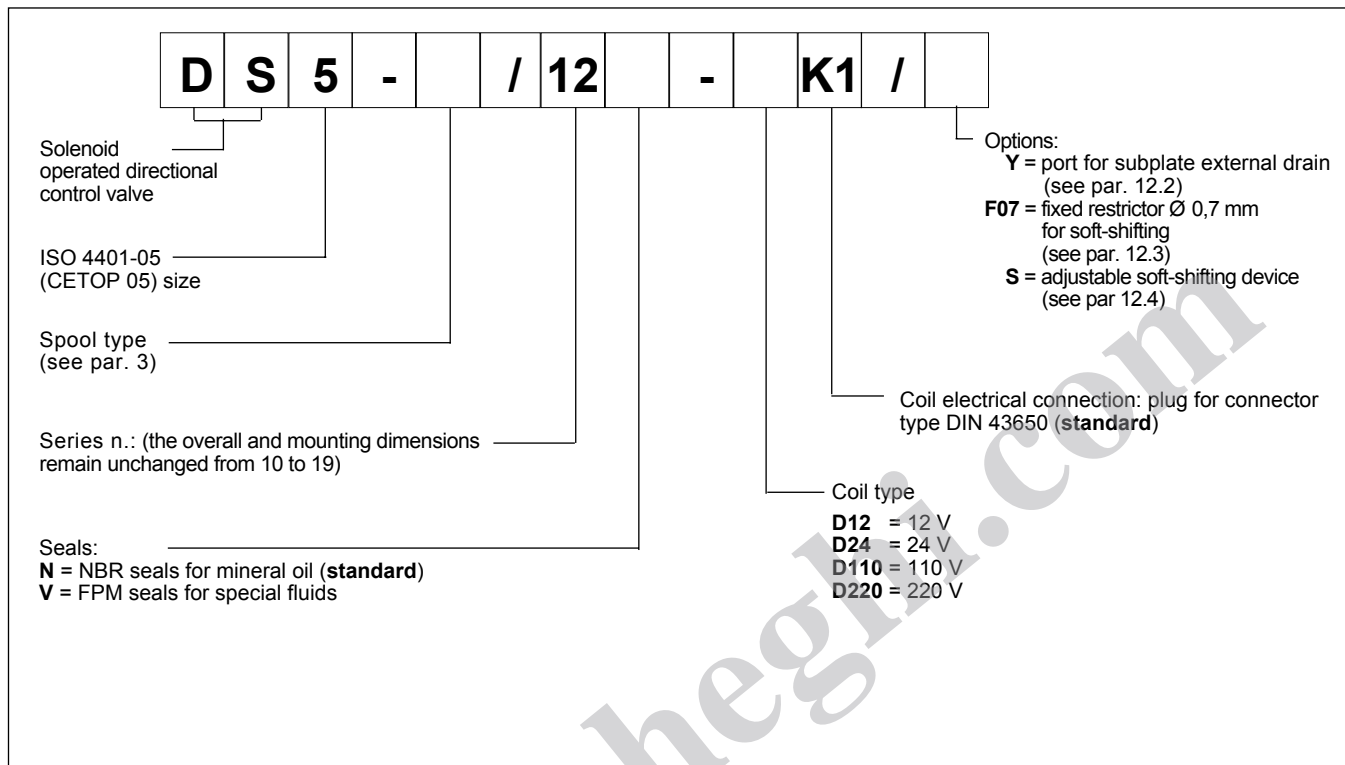

12.2 - Subplate external drain port (option Y)

This version allows the operation with pressures up to 320 bar on the valve T port.

It is a drain port Y realized on the valve mounting interface in compliance with ISO 4401-05-05-0-94 (CETOP 4.2-4-R05). The Y port is connected with the solenoid chamber: in this way the tubes are not stressed by the pressure operating on the valve T port.

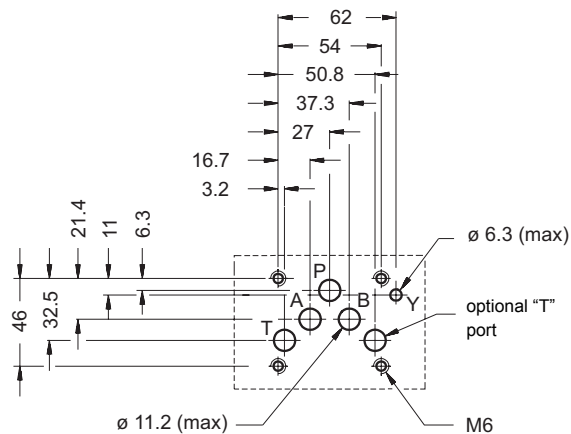



12.3 - Fixed restrictor for soft-shifting (option /F07)

This version enables hydraulic actuators to perform a smooth start and stop by reducing the speed of movement of the valve spool.

The spool speed is reduced by means of a restrictor with a calibrated orifice ② installed in the valve body. These restrictor can't be replaced. To change the restrictor, it is necessary to remove the coil and unscrew the plug 1/16" NPT ①.

The shifting time, with the same calibrated orifice, is influenced by the viscosity (and thus by the temperature) of the operating fluid.

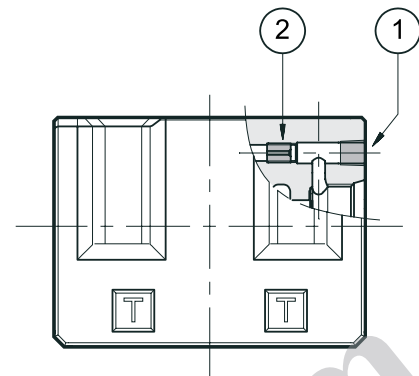

① = hole closure plug

② = M6x8 restrictor with calibrated orifice 0,7 mm

The table shows the switching times related to the S1 and S3 versions with restrictor \varnothing 0,7. For other versions please consult our Technical Department.

The values indicated are obtained according to ISO 6403 standard, with mineral oil viscosity 36 cSt at 50°C.

SPOOL TYPE	TIMES	
	ENERGIZING	DE-ENERGIZING
S1	250 ms	150 ms
S3		

12.4 - Directional solenoid valve with adjustable "soft-shifting" device (option /S)

This solenoid valve is supplied with a suitable device, adjustable by the user, which enables the control of the valve spool shifting time. In this way the hydraulic actuators can perform smooth movements, by controlling the valve switching time according to the machine cycle and the inertia of the moving parts.

NOTE: during the first start-up the valve body must be filled with the operating fluid through the tap ①.

① = plug spanner 17 mm - tightening torque 20 Nm

② = shifting time adjustment screw
countersunk hex spanner 2,5 mm

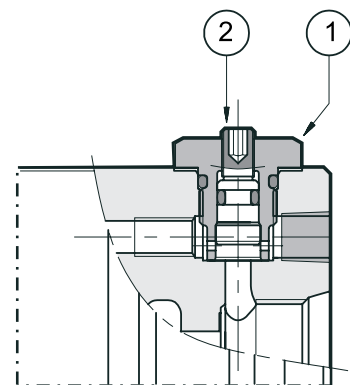



13 -SPARE PARTS FOR DC SOLENOID VALVE

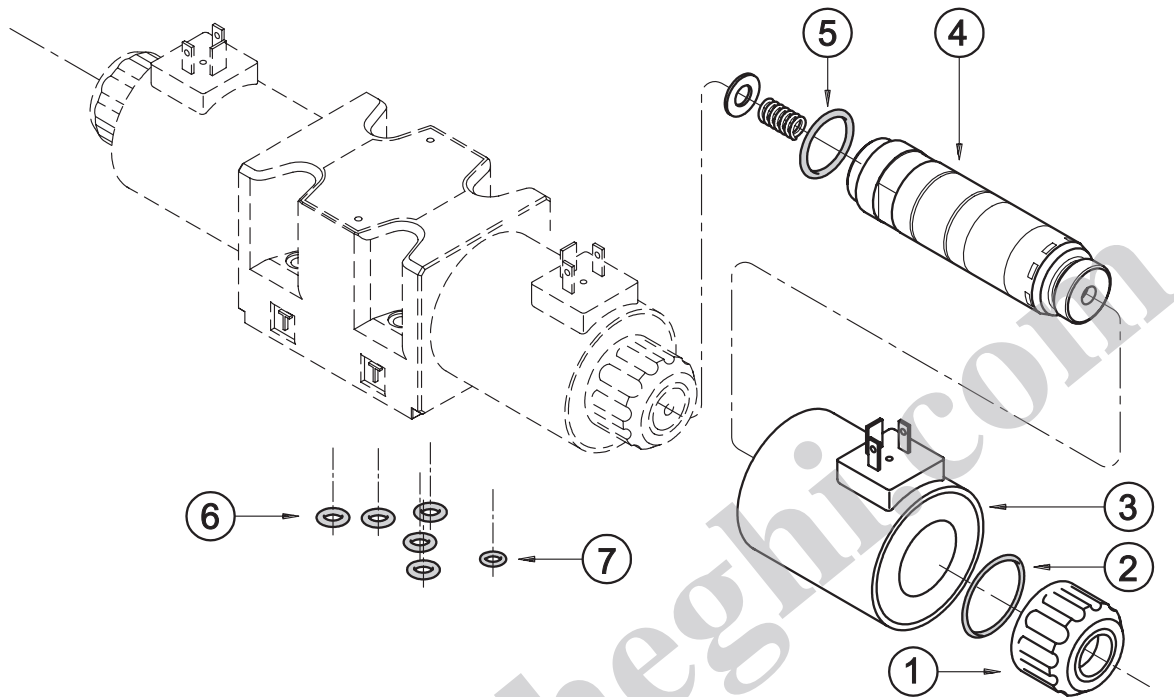

①	Coil locking ring with seal included cod. 0119383
②	ORM type 0320 - 25 - 70 Shore
③	Coil (see identification code on the side)
④	Solenoid tube TD31-M27/20N (NBR seals) TD31-M27/20V (FPM seals) Note: the solenoid tube is supplied with O-Ring rif. ⑤
⑤	O-Ring type 3-912 - 70 shore
⑥	N. 5 O-Ring type 2050 - 90 shore
⑦	O-Ring type 2037 - 70 Shore only for version with external subplate drain (option /Y)

DC COILS IDENTIFICATION CODE

C 31 - K1 / 20

Supply voltage
D12 = 12 V
D24 = 24 V
D110 = 110 V
D220 = 220 V

Series no.: (the overall
and mounting dimensions
remain unchanged from
20 to 29)

plug for connector type
DIN 43650 (**standard**)

SEALS KIT

The codes herebelow include O-Rings ref. ② ⑤ ⑥ ⑦

Cod. 1984418 NBR seals

Cod. 1984419 FPM (viton) seals



14 - SPARE PARTS FOR AC SOLENOID VALVE

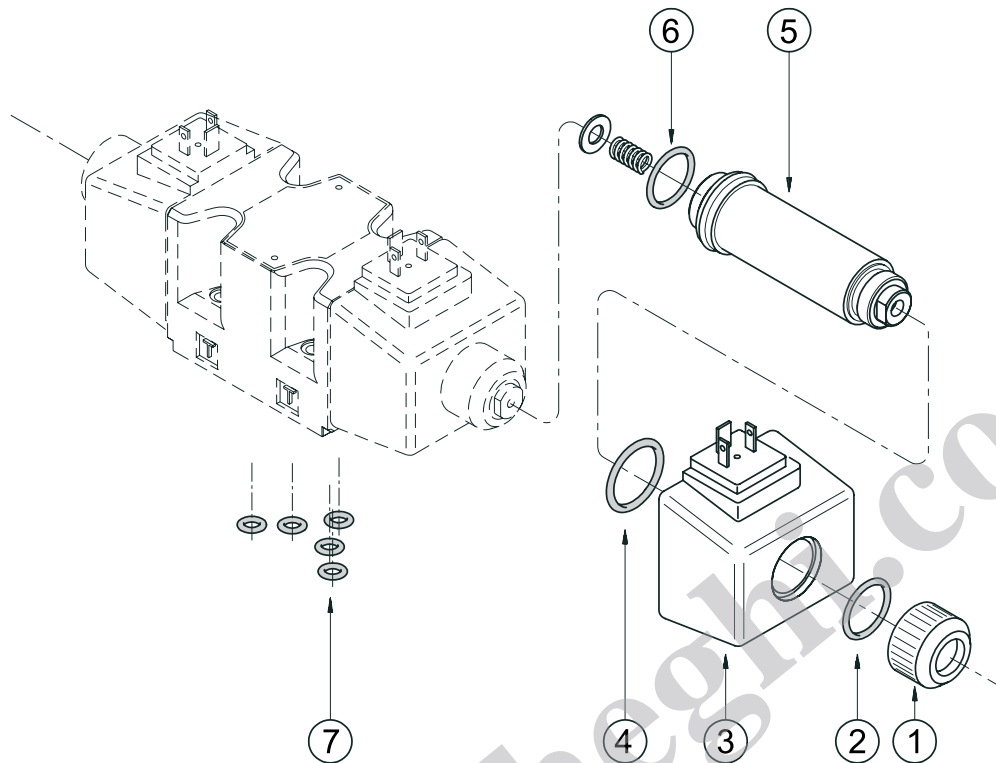

①	Coil locking ring cod. 0119402
②	O-Ring type 4100
③	Coil (see identification code on the side)
④	O-Ring type 2112
⑤	Solenoid tubes TA25.4-M27/10N (NBR seals) TA25.4-M27/10V (FPM seals) Note: the tube is supplied with O-Ring rif. ⑥
⑥	N. 2 O-Ring type 3-912 - 70 shore
⑦	N. 5 O-Ring type 2050 - 90 shore

AC COILS IDENTIFICATION CODE

C 254 - K1 / 11

Supply voltage

- A24** = 24 V - 50 Hz
- A48** = 48 V - 50 Hz
- A110** = 110 V - 50 Hz
= 120 V - 60 Hz
- A230** = 230 V - 50 Hz
= 240 V - 60 Hz
- F110** = 110 V - 60 Hz
- F220** = 220 V - 60 Hz

Series no.: (the overall and mounting dimensions remain unchanged from 10 to 19)

plug for connector type DIN 43650 (standard)

SEALS KIT

The codes herebelow include O-Rings ref. ② ④ ⑥ ⑦

- Cod. 1984420** NBR seals
- Cod. 1984421** FPM (viton) seals

15 - FASTENING BOLTS

4 bolts M6x40 (class 12.9 recommended)
Tightening torque 8 Nm

16 - SUBPLATES (See catalogue 51 000)

Type PMD4-AI4G with rear ports 1/2" BSP
Type PMD4-AL4G with side ports 1/2" BSP

 DIPLOMATIC HYDRAULICS	<p>DIPLOMATIC OLEODINAMICA SpA 20025 LEGNANO (MI) - P.le Bozzi, 1 / Via Edison Tel. 0331/472111 - Fax 0331/548328</p>
-------------------------------------	--